

FulFiller Container Loading Systems



High Speed Bulk Product Loading for ISO Containers

Introduction

Members of the Schenck Process Group, Stock Redler Ltd are leading providers of feeding, automation and bulk solids handling solutions.

The Schenck Process Group are global market leaders for solutions in measuring and process technologies in industrial weighing, feeding, screening and automation. Always close to the customer, with an unrivalled global network of operating companies we are your competent global partner for weighing, feeding, screening and automation solutions throughout the process industries.



Our philosophy is based on...

- ◆ Continuous product development
- ◆ Best practice approach to applications
- ◆ Raising industry standards



Capabilities

- ◆ Single machine
- ◆ Multiple machines
- ◆ System solutions
- ◆ Installation & commissioning
- ◆ Plant layout & integration
- ◆ Engineering & contract management
- ◆ Professional customer service approach



Industries

- ◆ Power, Coal, Steel, Cement, Mineral Chemical, Grain Processing, Brewing/Malting, Flour/Feed, Food, Particle Board, Waste Water Treatment

The Schenck Process Group develops, manufactures and markets a full range of solutions, products and turnkey systems on the basis of combining process engineering expertise, reliable components and field-proven technology.

Members of the Schenck Process Group are:



Bulk Shipping In Containers

The need to move bulk materials nationally and internationally is increasing as production operations consolidate and rationalize. To reduce shipping costs, logistics companies and manufacturers are making use of lined and unlined 20 and 40ft bulk containers for material transport.

Stock Redler has developed the FulFiller based on over 80 years of material handling experience. The FulFiller design reflects years of experience with our previous container loading system which established itself as the industry standard over the course of twenty years use by blue chip companies around the world.





FulFiller Container Loading made simple...

Belt Throwing Principle

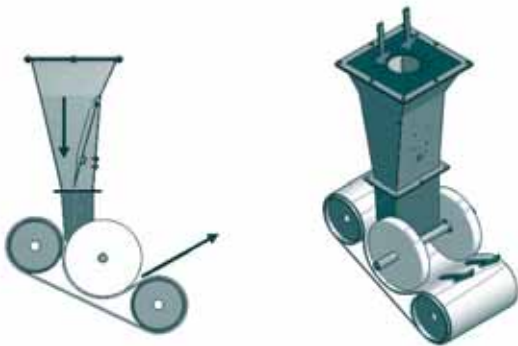

❖ The FulFiller uses a throwing belt which is supported on two rollers and rotates at high speed. The material being loaded falls onto the belt, is accelerated through 90° and thrown from the loader into the container. The throwing action minimises material degradation and is therefore ideal for all pellets and granules.

Key Dimensions

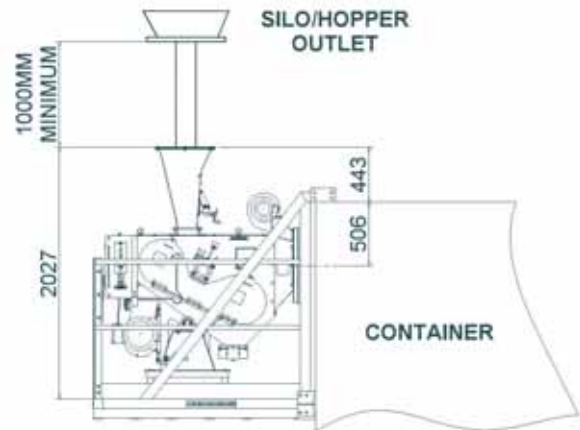

❖ The key dimensions shown are required to ensure the FulFiller operates efficiently. The height above the inlet is needed to ensure the quoted loading rates are achieved – the FulFiller will operate with lower headroom but with potentially reduced throughputs.

Materials Handled /Typical Capacities

The following materials are examples of those handled by the FulFiller and in a typical installation will be loaded at the rates shown:

❖ Plastic granules	100 Te/hr	❖ Pellet feeds and meals	100 Te/hr
❖ Chemical / fertilizer granules	120 Te/hr	❖ Soya beans	150 Te/hr
❖ Wood pellets	80 Te/hr	❖ Refined sugar	200 Te/hr
❖ Grain	90 Te/hr	❖ Rice	140 Te/hr

The high speed FulFiller allows a 20' container to be loaded in just 10 minutes.

Many other materials can be loaded using the FulFiller – contact us to discuss your application.

FulFiller trials at your site can also be organised for tests on your materials, normally on a free of charge basis.



Standard Mounting Options



MFF
Mobile Forklift Frame



CFF
Customer Fixed Frame



DMF
Dedicated Mobile Frame

- ❖ The thrower assembly can be mounted on a Forklift Frame for maximum flexibility in operation. The frame locates to the standard container lugs and guarantees that the thrower is in the optimum position for loading. Once mounted, the container and FulFiller can be driven under the required silo and connected. The unit is supplied ready to use and comes complete with a power cable and plug for connection to a local power supply.

- ❖ For single silo operations, the thrower can be mounted on a fixed platform and permanently connected to the silo and power supply. The container is reversed into position and the thrower outlet position adjusted using the hydraulic lift and turntable before connection of the liner to the thrower outlet.

- ❖ For multiple silo, driver controlled operations – or where no forklift is available – the thrower can be mounted on a mobile platform. The platform is moved under the required silo and connections made to the silo drop chute before the container is reversed into position and the liner connected to the thrower outlet.

* Alternative custom designs also available

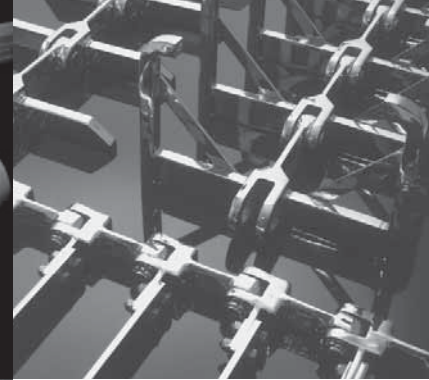

**FloMaster
Circular Bin Discharger**

- ❖ Fitted beneath circular silos or bins for the positive discharge of difficult materials
- ❖ No bridging or blockage at the silo outlet
- ❖ Compact construction
- ❖ Versatile in material control
- ❖ Single, Two or Three Stage units
- ❖ Totally enclosed
- ❖ Safe/good access for maintenance



Other Redler Technologies

**MoveMaster
Conveyors & Elevators**

Where industrial processes require materials to be transported horizontally, vertically or up inclines, Stock Redler Ltd select the appropriate equipment based on a careful analysis of each specific set of conditions within the process.

- ❖ Capacities 1-2000 tonnes per hr
- ❖ Worldwide references

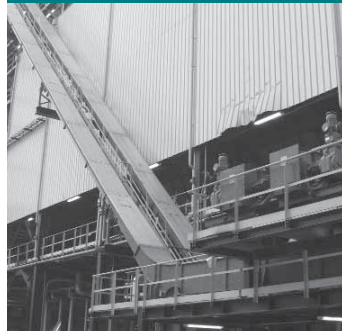

**IntraBulk
Bulk Reception Unit**

- ❖ Above ground intake
- ❖ Feed from road vehicle or loader
- ❖ Fast vehicle turn around time
- ❖ Can act as a buffer store
- ❖ Controlled discharge into process
- ❖ Modular heavy duty construction
- ❖ Quick installation & commissioning



**MaxiStore
Bridge Distribution System**

- ❖ Portside or inland applications
- ❖ Used within new or existing storage facility
- ❖ Redler® En Masse conveying principle
- ❖ Even distribution throughout the store
- ❖ Maximises storage capacity



**PortBulk
Mobile Reception Hopper**

- ❖ Portside applications
- ❖ Grab entry into hopper
- ❖ Integral dust suppression
- ❖ Heavy duty construction
- ❖ Outloading to vehicles
- ❖ Outloading to transfer system



Modular Configuration

To exactly match your requirements, the FulFiller can be configured using individual components:

Thrower

- ❖ The basic thrower is ATEX certified for Zone 22 use and is supplied with a fixed speed drive suitable for either 50 or 60Hz 3 phase power supplies. Variable speed drives are available for certain applications on request. Built into the thrower assembly is a radial fan for inflation of container liners.

Mounting Frame

- ❖ The thrower is mounted on one of three standard frames – MFF, CFF & DMF variants. Additional non-standard mounting arrangements can be considered on request.

Controls

- ❖ The standard control panel is ATEX certified for Zone 22 use and is supplied mounted on the thrower assembly. The operator interface is provided by a hand held controller that is connected to the main panel by a 5m long cable.

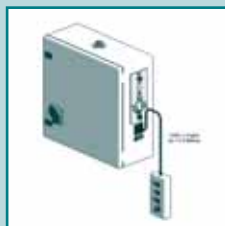

Hydraulic Lift

- ❖ For use with either fixed or mobile platforms, this allows vertical adjustment of the thrower outlet to match differing trailer and container heights. The lift is hydraulically operated, powered from the main control panel and has a lift range of 800mm.



Turntable

- ❖ For use with fixed or platforms, this allows directional adjustment of the thrower outlet to offset misalignment of the container.



weighing

feeding

conveying

automation

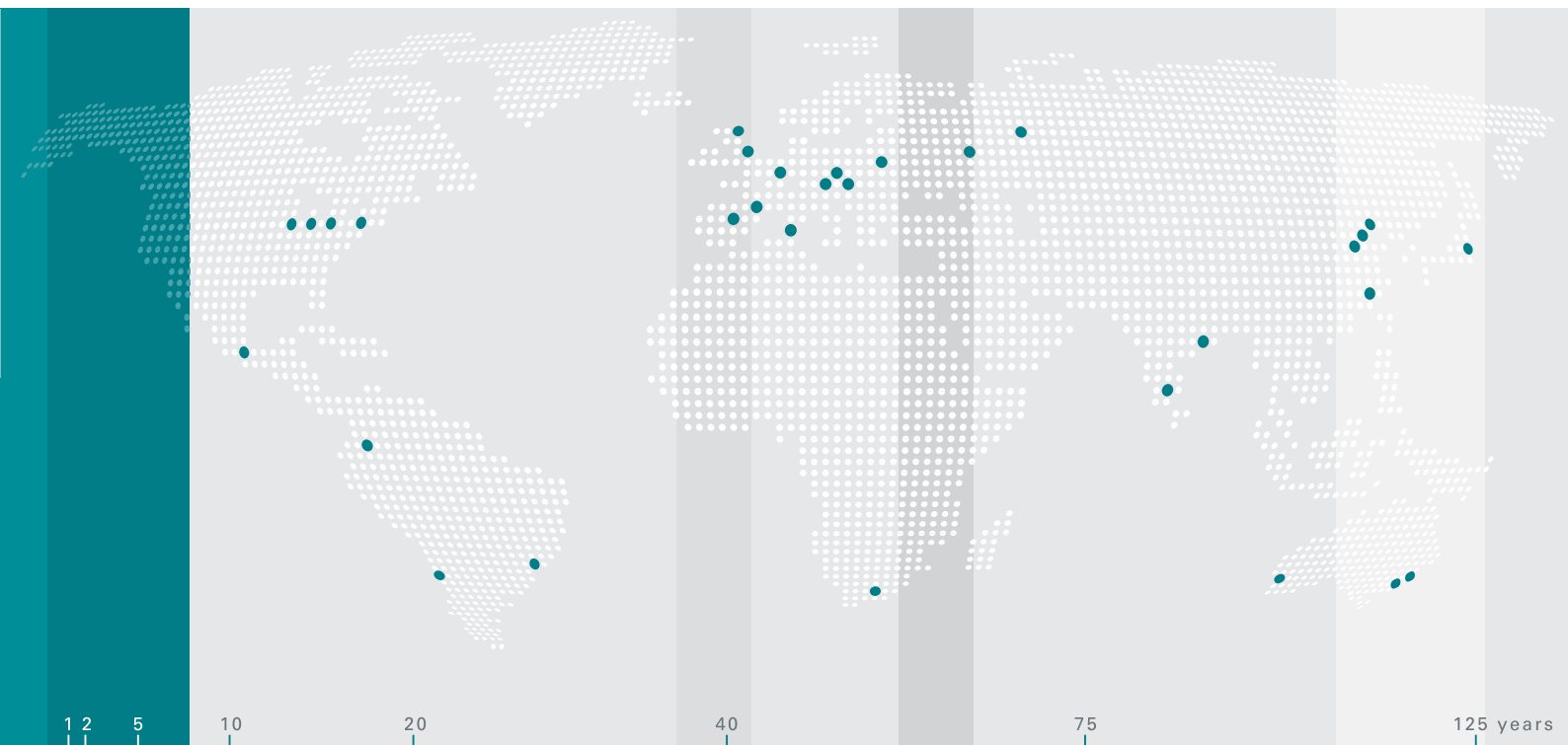

Stock Redler Limited
Redler House
Dudbridge, Stroud
Gloucestershire
GL5 3EY England
T +44 (0) 1453 763 611
F +44 (0) 1453 763 582
sales@redler.com
www.redler.com

Schenck Process GmbH
Pallaswiesenstraße 100
64293 Darmstadt
Germany
T +49 61 51-15 31 0
F +49 61 51-15 31 11 72
sales@schenckprocess.com
www.schenckprocess.com



we make processes work